



# 12.8V 50AH LiFePO4 Battery User Manual



# Content

<b>1. Scope .....</b>	<b>2</b>
<b>2. Product Description .....</b>	<b>2</b>
<b>3. Battery Pack Basic Characteristic .....</b>	<b>2</b>
<b>4. Battery Mechanical Characteristics .....</b>	<b>3</b>
<b>5. Battery Safety Characteristics .....</b>	<b>4</b>
<b>6. BMS/PCM Specification .....</b>	<b>5</b>
<b>7. BMS/PCM Functions Brief Diagram .....</b>	<b>6</b>
<b>8. Product Scheme and Characteristic .....</b>	<b>7</b>
<b>9. Storage Conditions.....</b>	<b>8</b>
<b>10. Product Responsibility.....</b>	<b>8</b>
<b>11. Battery Handling Precautions.....</b>	<b>8</b>
<b>12. Special Considerations.....</b>	<b>9</b>

## 1. Scope

This product specification describes the requirements for the rechargeable Lithium LiFePO4 Battery pack with protection circuit for detecting function of over-charge, over-discharge, over current etc. which be manufactured and supplied by Guangzhou Cooli New Energy Technology Co., LTD

## 2. Product Description

2.1 Cell type: Prismatic cell with 50Ah

2.2 Battery type : 1P4S battery with BMS

## 3. Battery Pack Basic Characteristic

	Item	Specification	Method
1	Cell Type	3.2V 50Ah	
2	Array Mode	1P4S	
3	Nominal Capacity	50Ah	Standard charge and discharge
4	Nominal Voltage	14.6V	
5	Energy	0.64KWh	
6	AC Impedance	$\leq 30\text{m}\Omega$	At 1kHz with 100%SOC
7	Charging Voltage	14.6V	
8	Discharge End Voltage	10V	
9	Standard Charging Method	20A(0.2C)	
10	Max.Charge Current	50A(1C)	
11	Standard Discharging Method	50A(0.5C)	
12	Max.Discharge Current	50A(1C)	

13	Cycle life	$\geq 6000$ cycles	0.2C Charge , 0.5C discharge @80% DOD , the Capacity Retention $\geq 80\%$ of initial capacity			
14	Operating Temperature	0°C~50°C	Charging Operating			
		-20°C~50°C	Discharging Operating			
15	Storage Characteristic	1 month	Temperature -20°C~50°C			
		3 months	Temperature -20°C~45°C			
		One year	Temperature -20°C~20°C			
16	Relative Humidity for Storage	5%~95%				
17	Charge Retention and Capacity Recovery Characteristic	Charge Retention Rate $\geq 55\%$ and Capacity Recovery Rate $\geq 80\%$ .	Storage the battery for 20d at 60°C after fully charge with standard charge method.			
18	Discharge Capacity at Different Temperature after Standard fully Charging	Discharge Temperature	-20°C	0°C	23°C	55°C
		Discharge Capacity (0.3C)	$\geq 70\%$	$\geq 80\%$	100%	$\geq 95\%$

#### 4. Battery Mechanical Characteristics

No.	Item	Specification	Test Method and Condition
1	Vibration Test	No explosion, No leakage and No fire.	<p>Fully charged batteries are vibration-tested under the following test conditions.</p> <p>Simple harmonic motion is applied to the batteries with amplitude of 0.76mm , and a total maximum excursion of 1.52mm. The frequency is varied at the rate of 1 Hz/min between the limits of 10 Hz and 55 Hz. The entire range of frequencies ( 10 Hz to 55 Hz) and return (55 Hz to 10 Hz) is traversed in 90 min <math>\pm</math> 5 min for each mounting position (direction of vibration) . The vibration is applied in each of three mutually perpendicular directions , in the sequence specified below.</p> <p>Step 1: Verify that the measured voltage is typical of the charged product being tested.</p> <p>Steps 2-4: Apply the vibration as specified in Table.</p> <p>Step 5: Rest battery for 1h. Then make a visual inspection.</p>

2	Drop Test	No explosion, No leakage and No fire.	After standard charging, the battery is to be dropped from a height of 1 meter twice onto concrete ground.
---	-----------	--	--

## 5. Battery Cell Safety Characteristics

No.	Item	Specification	Test Method and Condition
1	Short Circuit Test	No explosion, No fire and the Temperature of the surface of battery is lower than 150°C	After standard charging and put the battery into a fume hood, and connect the Negative terminal and Positive terminal directly with a Cu wire (the wire's resistance should be lower than 50mΩ). Record the surface temperature of battery during the test and stop the test when the temperature decreases to about 10°C lower than the peak temperature during whole test. Note : this test is performed without PCM
2	Heating Test	No explosion , No fire	After standard charging and put the battery into oven convection or circulating air oven. The temperature of oven is to be raised with a rate of 5±2°C/min to a temperature of 130±2°C and last for 10 minutes.
3	Impact Test	No explosion , No fire	The fully charged battery is secured to the testing machine by means of a rigid mount which will support all mounting surfaces of the battery. The battery is subjected to a total of three shocks of equal magnitude. The shocks are applied in each of three mutually perpendicular directions. At least one of them shall be perpendicular to a flat face. For each shock the battery is accelerated in such a manner that during the initial milliseconds the minimum average acceleration is 75 gn. The peak acceleration shall be between 125 gn and 175 gn. Batteries are tested in an ambient temperature of 25°C±3°C.
4	Over Charge Test	No explosion , No fire	After standard charging and put the battery in fume hood. Add constant voltage& current 3.9V 1C to the battery. Charging it until the battery reaches 5V, charging current decreases to almost 0A. Record the temperature curve of the battery and stop test when the battery temperature decreases to about 10 °C lower than the peak temperature during whole testing. This test is performed without PCM.

## 6. BMS/PCM Specification

No.	Item	Specification	Parameter
1	Cell over-discharge protection	Over-discharge detection voltage	2.50V
		Over-discharge detection delay time	Typical:1.0s
		Over-discharge release voltage	2.90V or charge
2	Pack overcharge alarm	Pack Overcharge alarm voltage	14.5V
		Pack alarm release voltage	14.5V
3	Pack overcharge protection	Pack Overcharge detection voltage	14.6V
		Overcharge detection delay time	Typical:1.0s
		Overcharge release voltage	14.2V
4	Pack over-discharge alarm	Pack Over-discharge alarm voltage	10V
		Pack alarm release voltage	10V
5	Pack over-discharge alarm	Pack Over-discharge detection voltage	9V
		Over-discharge detection delay time	Typical:1.0s
		Over-discharge release voltage	10V or charge
6	Over-current alarm	Discharge Over-current alarm current	100A
		Discharge Over-current protection current 1	110A
		Discharge Over-current protection current 2	110A
		Discharge Over-current detection delay time 2	≤400ms
		Charge Over-current alarm current	95A
		Charge OC protection current	100A
7	Short protection	Short protection current	560A
		Protection condition	Load short
		Detection delay time	≤300us
		Protection release condition	Charging release

8	Balance	Balance threshold voltage	3.50V
9	Alarm	It has over-temperature, over charge, under-voltage, over-current, short circuit alarm function	

### Charging current limiting condition:

(1)The charging will automatically enter the current-limiting mode, and the charging will be switched to normal charging after 5 minutes;

(2)If the charging current alarm or charging overcurrent protection occurs during normal charging, it will automatically enter the charging current limit mode;

(3)When the highest voltage of the cell reach to the end-of-charge voltage, it automatically enters the current-limit charging mode;

The current limiting mode can also be turn off by the RS485 software

Notes: This charging and current limiting mechanism is only limited to the software protection board scheme. For other functional indicators of the protection module, please refer to the detailed technical specifications of the protection board.

### 7. BMS/PCM Functions Brief Diagram

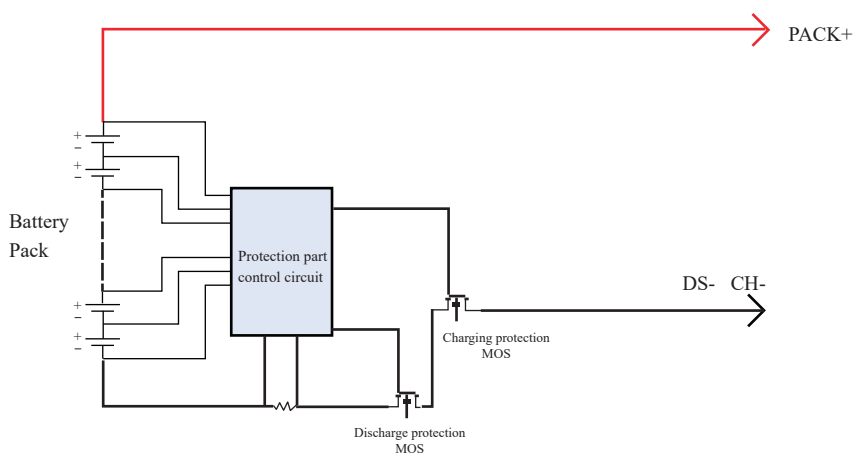

Note: The above is just the principle of common function protection module design, the actual product is perhaps not be matched to the diagram because different customer requirements.

## 8. Product Scheme and Characteristic

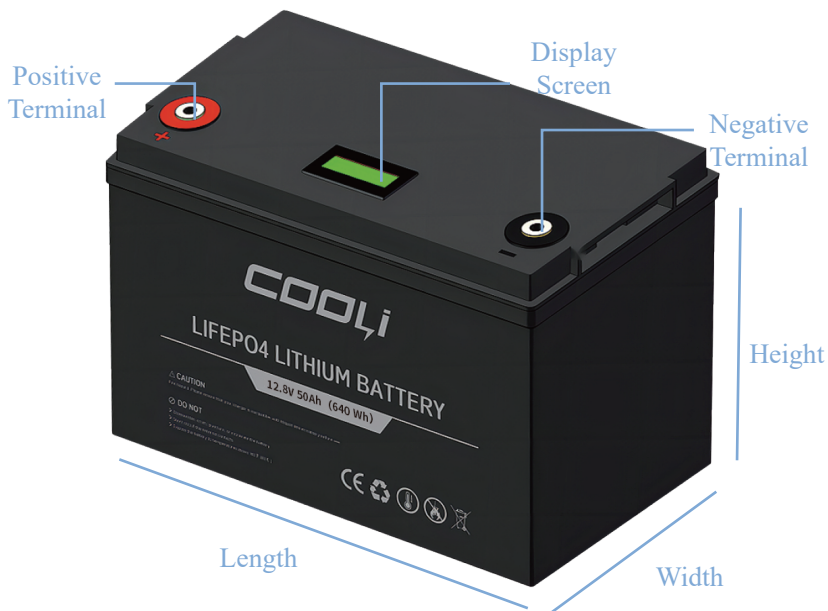

No.	Item	Specification	Notes
1	Product Size: Length	229±0.5mm	Including the size of the upper cover
2	Product Size: Width	138±0.5mm	Including the size of the upper cover
3	Product Size: Height	208±0.5mm	Including the size of the upper cover
4	Discharge/Charge Port	M8 (adjustable)	
5	Product Weight	≈8 Kg	
6	Output terminal	Copper terminal block	As shown in the figure
7	Delivery Capacity	50%~60%SOC	



## 9. Storage Conditions

- ◆ For long time storage ,the battery should be charged to Approx 60% SOC ,its corresponding voltage should be 1.05times of nominal voltage(12V,24V,36V,60V or 72V),usually it's voltage in shipment .The battery should be kept in storage in dry and ventilated place.
- ◆ The battery pack and charger should be stored in clean, dry and ventilated place, avoid contacting with corrosive materials and be away from fire and heat.

## 10. Product Responsibility

- ◆ We assume no responsibility for the accident of not operating in accordance with the specification.
- ◆ If the specifications, raw materials, production process or production control systems is changed, the change will vary depending on the quality and reliability of data written notice to the customer.

## 11. Battery Handling Precautions

- ◆ Don't immerse battery in water or allow it to get wet!
- ◆ Don't charge, use and store battery near a heat source such as fire heater! If the battery leaks or releases strange odor, please remove it from place near fire place immediately. Fully charge the battery before first-time using.
- ◆ Don't reverse the positive and negative pole of battery!
- ◆ Don't throw the battery into fire or heat it!
- ◆ Don't short-circuit battery with wire or other metal objects !
- ◆ Don't nail, knock or trample the battery!
- ◆ Don't disassemble the battery in any way!
- ◆ Don't put the battery into microwave oven or pressure vessel!
- ◆ If the battery gives off odor, gets heat, deformation, discoloration or appears and abnormal behaviors, stop using it. Please remove the battery from electrical appliances and stop using it if the battery is being used or charged!
- ◆ Don't use battery in a very hot environment, such as under direct sunlight or in car on hot day. Otherwise, the battery will overheat which will affect battery performance and shorten battery life !
- ◆ If the battery leaks and electrolyte leakage enters into the eyes, don't rub, rinse with water immediately and seek immediate medical assistance. If not in time, eyes will be hurt!
- ◆ Ambient temperature will affect the discharge capacity of battery, if the ambient temperature is beyond the standard environment ( $23\pm 2^{\circ}\text{C}$ ), the discharge capacity will be changed.

◆ Do not connect batteries in series or parallel at the same time.

When connected in series, the number of batteries is  $\leq 4$

When connected in parallel, the number of batteries is  $\leq 4$

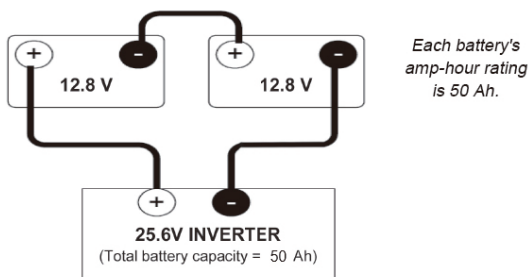

(Battery Wiring In Series Configuration)

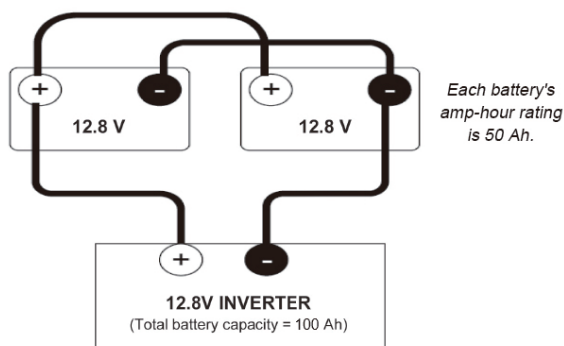

(Battery Wiring In Parallel Configuration)

## 12. Special Considerations

- ◆ During charging process, if there has odor or unusual noise, please stop charging immediately.
- ◆ During discharging process, if there has odor or unusual noise, please stop discharging immediately.
- ◆ If there have above behavior during your using process, please contact the Cooli, do not disassemble by yourself.

For the above contents of the specification, Guangzhou Cooli New Energy Technology Co., LTD has the final interpretation right. If there is any change, we will notify the user in advance.

The logo for Cooli features the word "COOLI" in a bold, italicized, sans-serif font. The letters "C", "O", "O", "L", and "I" are dark blue, while the letter "I" is green and has a lightning bolt shape integrated into its right side.

**COOLI**

**Guangdong Cooli New Energy Technology co., Ltd.**